

RETAINER 50 Kg FOR BUILT-IN AE/V-R2450E

Description

The function is to keep the access doors or fire doors open and automatically release them in the event of a fire. They consist of two parts, the electromagnet itself and the plywood. They have an unlock button that can be installed on both sides. The electromagnet is embedded in the wall and the plywood in the door.



Dimensions

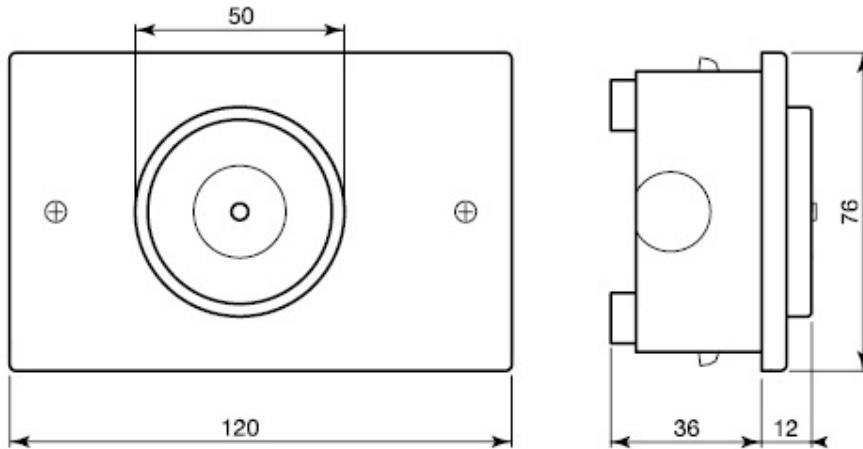

TECHNICAL CHARACTERISTICS

Material:	Galvanized Aluminum
Operating temperature:	-10°C + 55°C
Protection degree:	IP40
Power:	24Vdc
Consumption:	45mA
Clamping force:	50Kg / 490N